

SINGER
110W115,W120

Form 1850 w

October, 1923

PRINTED IN U. S. A.

LIST OF PARTS



MACHINES

Nos. 110w115 and 110w120

THE SINGER MANUFACTURING COMPANY

COPYRIGHT, U. S. A., 1919, 1922 AND 1923,
BY THE SINGER MANUFACTURING CO.
ALL RIGHTS RESERVED FOR ALL COUNTRIES

INDEX

	PAGE
ACCESSORIES	28
BOBBIN WINDER	28
FEED GEARS	31
" WHEELS	32
GUIDES	32
KNEE LIFTER	29
MACHINE No. 110w115	7
" " 110w120	18
NUMERICAL LIST OF PARTS	35
OBSOLETE PARTS	34
THROAT PLATES	33

Instructions for Ordering

In ordering from this list, use **ONLY** the **PART** number in the **FIRST** column.

The number stamped on a Sewing Machine Part is the number of the Single Part only, except when the part includes Set Screws, Clamping Screws, Studs and Rollers Spun on, Small Wires riveted, or Parts soldered together, etc., which it is necessary to furnish in combination.

Every combination of parts sent out has its specific number which, although not stamped on Parts (except in above cases) must be used when ordering the combination.

Each number always indicates the **SAME PART** in whatever list it appears, or for whatever Machine.

The letters after some of the numbers indicate the style of finish only, as follows:

- A. Hardened, Polished and Plated.
- B. Polished and Plated.
- C. Hardened only.
- D. Polished only.
- E. Soft, not polished.
- F. Hardened and Polished.
- H. Blued.

These letters **MUST BE USED** when they appear in the list and **AFTER** the number, as in the list.

In this series

200001 to 201500 are Screw Numbers.

201501 to 201800 are Nut Numbers.

201801 to 202000 are Roller Numbers.

202001 and upward are numbers of Machine Parts.

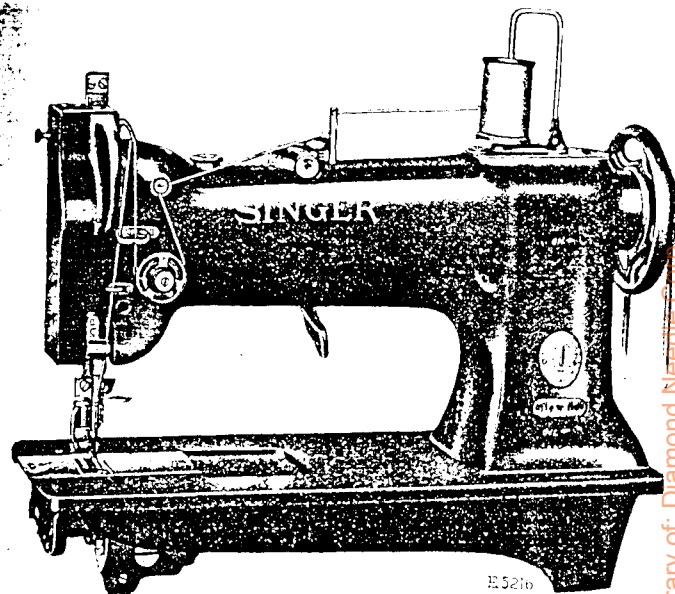
The figures in the second column refer only to the plate in which the illustration of the part is shown and are **NOT TO BE USED** in ordering.

Two or more numbers over a cut indicate that the difference between such parts is not visible in an illustration.

Parts marked with an asterisk (*) are furnished only when repairs are made at the factory.

LIST OF PARTS COMPLETE

FOR



MACHINE No. 110w115

VERTICAL HOOK. ROLLER PRESSER.

CONTINUOUS WHEEL FEED.

VERTICAL TRIMMER

For Leather Work

No.	Plate	Name
*237801	—	Arm
203091	14186	" Cap
200273H	14176	" " Screw
202248	14176	" " " Washer
203089	14186	" " Spool Holder Base
203090	14186	" " " " " 203089 with 200079H and 204296
200585H	14187	Arm Cap Spool Holder Base Screw
204296	14186	" " " " Wire
200079H	14187	" " " " " Hinge Screw

From the library of: Diamond Needle Corp

No.	Plate	Name
203092	—	Arm Cap and Spool Holder complete, Nos. 203090, 203091 and two 200585H
204235	14187	Arm Position Pin (2)
200004E	14176	" Screw
200010E	14176	" " (2)
202005	14176	" " Washer (3)
202632	14186	" Side Plate
200462B	14176	" " Thumb Screw
237802	14189	" Shaft with 200357E and 203100
237748	14186	" " Bushing (back) with 202299
202299	—	Arm Shaft Bushing (back) Oil Packing (wick)
200071E	14176	Arm Shaft Bushing (back) Screw (3)
202245	14186	Arm Shaft Bushing (front) with 202036 and 202260
202260	—	Arm Shaft Bushing (front) Oil Packing (wick)
200502B	14176	Arm Shaft Bushing (front) Oil Packing Thumb Screw
202036	14176	Arm Shaft Bushing (front) Position Pin
200338C	14176	Arm Shaft Bushing (front) Set Screw
203100	—	Arm Shaft Oil Packing (wick)
200357E	14176	" " " " Stop Screw
223842	14189	Balance Wheel (belt groove 2 3/4 in. diam.) with 200328c and 200335c
200062H	14176	Balance Wheel Adjusting Screw
200328c	14176	" " Position Screw
200335c	14176	" " Set Screw
*237803	—	Bed
202258	12345	" Hinge Connection (2)
200570E	14176	" " " Screw (4)
237901	14186	" Slide (back)
237706	14186	" " (front)
203470	14176	Bobbin
*203520	—	" Case
203648	14176	" " Latch
*202056	—	" " " Pin
203473	14176	" " " Plunger
203474	14176	" " " Spring
236078	14176	" " Lever
203476	14176	" " " Eccentric
204243	14176	" " " " Position Pin
235751	14176	" " " Fulcrum
200056D	10884	" " " " Screw
203478	14176	" " " Slide Stud

No.	Plate	Name
203214	14176	Bobbin Case Tension Spring
200984c	14176	" " " " Regulating Screw
200594c	14176	Bobbin Case Tension Spring Screw
203216	—	" " Washer (cloth)
203521	14176	Bobbin Case complete, Nos. 200594c, 200984c, 202056, 203214, 203216, 203473, 203474, 203520 and 203648
237804	14186	Face Plate
202135	14176	" " Position Pin
200473B	14176	" " Thumb Screw
237707	14190	Feed Wheel
350085F	14179	" " Adjusting Screw
237708	14179	" " " " Block
237709	14180	" " Bracket
237710	14179	" " " Spring
237713	14179	" " Driving Gear with 200382c and 201220c (for 16 stitches)
201220c	14187	Feed Wheel Driving Gear Position Screw
200382c	14179	Feed Wheel Driving Gear Set Screw
237718	14179	" " " Pinion with 200382c and 201220c (for 16 stitches)
201220c	14187	Feed Wheel Driving Pinion Position Screw
200382c	14179	Feed Wheel Driving Pinion Set Screw
237721	14189	Feed Wheel Driving Shaft
237722	14179	" " " " Bushing (back)
237723	14179	Feed Wheel Driving Shaft Bushing (front)
200362c	14179	Feed Wheel Driving Shaft Bushing Set Screw
221743	14179	Feed Wheel Driving Shaft Collar with two 200380c
200380c	14179	Feed Wheel Driving Shaft Collar Set Screw
237724	14179	Feed Wheel Driving Shaft Gear with 200378c and 201220c
201220c	14187	Feed Wheel Driving Shaft Gear Position Screw
200378c	14179	Feed Wheel Driving Shaft Gear Set Screw
237725	14179	Feed Wheel Stud
201697c	14179	" " " Nut

No.	Plate	Name
*203482	—	Hook (sewing)
237726	14181	" 203482 with 201253F, 201376F and 221148
237727	—	Hook and Bobbin Case complete, Nos. 203521 and 237726
235755	14181	Hook Bevel Gear Socket, 18 teeth
235527	14181	" " " " Bushing (lower) (brass)
200362c	14179	Hook Bevel Gear Socket Bushing (lower) Set Screw
235756	14181	Hook Bevel Gear Socket Bushing (upper) (brass)
449c	14181	Hook Bevel Gear Socket Bushing (upper) Set Screw
200555H	14181	Hook Bevel Gear Socket Screw ..
235635	14181	" " " " Thrust Washer
235529	14181	Hook Driving Bevel Gear with two 350089c
350089c	14181	Hook Driving Bevel Gear Set Screw
237728	14190	" " Shaft
235857	14181	" " " Bevel Gear with 200374c and 200396c
237729	14180	Hook Driving Shaft Bevel Gear Housing with 200346c and three 200362c
237730	14180	Hook Driving Shaft Bevel Gear Housing Cap (bottom)
237731	14180	Hook Driving Shaft Bevel Gear Housing Cap (bottom) Gasket ..
237732	14180	Hook Driving Shaft Bevel Gear Housing Cap (side)
237733	14180	Hook Driving Shaft Bevel Gear Housing Cap (side) Gasket
200053c	14181	Hook Driving Shaft Bevel Gear Housing Cap Screw (4)
201082E	14181	Hook Driving Shaft Bevel Gear Housing Screw (long)
225532	14187	Hook Driving Shaft Bevel Gear Housing Screw (long) Washer..
201308E	14181	Hook Driving Shaft Bevel Gear Housing Screw (short)
200396c	11607	Hook Driving Shaft Bevel Gear Po- sition Screw
200374c	14181	Hook Driving Shaft Bevel Gear Set Screw
237734	14181	Hook Driving Shaft Bushing (back)
200362c	14179	" " " " " Set Screw

No.	Plate	Name
235531	14181	Hook Driving Shaft Bushing (front)
200347c	14181	" " " " " Set Screw
221743	14179	Hook Driving Shaft Collar with two 200380c
200380c	14179	Hook Driving Shaft Collar Set Screw
221148	14181	Hook Gib
201376F	14181	" " Hinge Screw
201253F	14181	" " Screw
237735	14180	" Saddle with 449c, 200347c and three 200362c
235534	14182	Hook Saddle Oil Cover
201185D	14182	" " " " Screw (2)
201318E	14182	" " " Stop Screw (2)
235535	—	" " Oiling Felt
202260	—	" " " Wick
235649	14182	" " " " Cover
200169H	14182	" " " " " Screw
201308E	14181	" " Screw (2)
213018	—	" Washer
203507	14182	" " 213018 with 203476 and two 204243
208490	14190	Knee Lifter Connection Lever
200262H	14182	" " " " Hinge Screw
237766	14190	Knee Lifter Connection Lever Lift- ing Rod with 202302
202302	14182	Knee Lifter Connection Lever Lift- ing Rod Cotter Pin
237805	14189	Knee Lifter Lifting Lever
200262H	14182	" " " " Hinge Screw
207805	14187	Knife
200397H	11610	" Adjusting Screw
237806	14190	" Bar
237807	14187	" " Angle Extension
200126E	14187	" " " " Screw (2)
221417	14190	" " Driving Eccentric with 200382c and 200437c
202890	14190	Knife Bar Driving Eccentric Fork with 200382c and 201464c
201464c	14187	Knife Bar Driving Eccentric Fork Position Screw
200382c	14179	Knife Bar Driving Eccentric Fork Set Screw
200437c	14187	Knife Bar Driving Eccentric Posi- tion Screw
200382c	14179	Knife Bar Driving Eccentric Set Screw

No.	Plate	Name
202891	14192	Knife Bar Driving Shaft Crank with 200694F and 201525E
203244	14187	Knife Bar Driving Shaft Crank Collar with two 200393c
200393c	14187	Knife Bar Driving Shaft Crank Collar Set Screw
200694F	14187	Knife Bar Driving Shaft Crank Screw Stud
201525E	14187	Knife Bar Driving Shaft Crank Screw Stud Nut
237808	14187	Knife Bar Guide Block
200011E	14187	" " " " Screw (2) ..
200337c	14187	" " " " Screw
201531E	14187	" " " " Nut
237829	14187	" " Lifting Spring
202346	14187	" " " " Plunger ..
237809	14191	" " " " Position Bracket
201387F	—	" " " " Screw (2) ..
237810	14191	" Holder with 200397H
200898D	14191	" " Screw
237811	14191	" " Switch-in Handle
200076D	14191	" Screw (2)
237812	14192	" Switch-out Handle with two 200373c
200373c	14191	Knife Switch-out Handle Set Screw
202899	14192	" " " " Shaft
202900	14191	" " " " Spring (spiral)
237822	14192	Needle Bar with 200389c
202552	11607	" " Connecting Link
223687	—	" " " " Oil Guard
200161D	11607	Needle Bar Connecting Link Oil Guard Screw
202333	11607	Needle Bar Connecting Link Stud with 202254
202254	—	Needle Bar Connecting Link Stud Oil Packing (wick)
200374c	11181	Needle Bar Connecting Link Stud Set Screw
200383c	14182	Needle Bar Connecting Link Stud Set Screw
*206891	—	Needle Bar Connecting Stud
202329	11607	" " " " 206891 with 200086c and 202330
202330	—	Needle Bar Connecting Stud Oil Packing (wick)
200086c	11607	Needle Bar Connecting Stud Pinch Screw

No.	Plate	Name
202692	14192	Needle Bar Crank with 200335c, 200374c, 200383c, 200428c and 202333
237737	—	Needle Bar Crank 202692 with 202329, 202399, 202400, 202552 and 237762
203172	11607	Needle Bar Crank Friction Washer
200428c	11607	" " " " Position Screw..
200335c	14176	" " " " Set Screw
237813	14192	" " " " Rock Frame
237814	—	" " " " 237813 with 237822
*38127	—	Needle Bar Rock Frame Driving Eccentric
*237749	—	Needle Bar Rock Frame Driving Eccentric Body
350107c	14191	Needle Bar Rock Frame Driving Eccentric Body Position Screw..
443c	14182	Needle Bar Rock Frame Driving Eccentric Body Set Screw
21331	14182	Needle Bar Rock Frame Driving Eccentric Pressure Spring
21332	14182	Needle Bar Rock Frame Driving Eccentric Pressure Spring Cap..
934D	14182	Needle Bar Rock Frame Driving Eccentric Pressure Spring Cap Screw
1103c	14182	Needle Bar Rock Frame Driving Eccentric Regulating Screw
217D	14191	Needle Bar Rock Frame Driving Eccentric Set Screw
7071	14191	Needle Bar Rock Frame Driving Eccentric Set Screw Washer ...
237750	—	Needle Bar Rock Frame Driving Eccentric complete, Nos. 217D, 443c, 934D, 1103c, 7071, 21331, 21332, 38127, 237749 and 350107c
237739	14192	Needle Bar Rock Frame Driving Fork Lever with 200029E
200029E	14182	Needle Bar Rock Frame Driving Fork Lever Pinch Screw
237740	14182	Needle Bar Rock Frame Driving Fork Lever Slide Block (two pieces)
210910	11607	Needle Bar Rock Frame Hinge Stud with 202277
202277	—	Needle Bar Rock Frame Hinge Stud Oil Packing (wick)
200347c	14181	Needle Bar Rock Frame Hinge Stud Set Screw

No.	Plate	Name
202667	14192	Needle Bar Rock Frame Rock Shaft
210978	—	“ “ “ “ “ “ 202667 with 200386c and 210920..
237815	14191	Needle Bar Rock Frame Position Bracket with 200337c and 201531E
350129E	14191	Needle Bar Rock Frame Position Bracket Screw (2)
202668	11607	Needle Bar Rock Frame Slide Block
210920	—	“ “ “ “ “ “ 202668 with 201141c
201141c	14182	Needle Bar Rock Frame Slide Block Screw Stud
200386c	11607	Needle Bar Rock Frame Slide Block Screw Stud Set Screw
200389c	11610	Needle Set Screw
207072	11607	Presser Bar Bushing (2)
200352c	14182	“ “ “ Set Screw (2)
202671	14182	“ “ Lifter
200653c	14182	“ “ “ Hinge Screw ..
202672	14191	“ “ Lifting Releasing Lev- er Bracket
200975F	14191	Presser Bar Lifting Releasing Lev- er Bracket Guide Screw
237765	14191	Presser Bar Lifting Releasing Lev- er Bracket Spring (spiral)
237820	14191	Presser Bar Position Guide
202338	14191	“ “ “ “ Lever with 200086F
200086F	11607	Presser Bar Position Guide Lever Pinch Screw
200352c	14182	Presser Bar Position Guide Set Screw
237821	14189	Presser Bar Spring (flat)
210949	14193	Presser Bar Spring Bracket with 200086c
200086c	11607	Presser Bar Spring Bracket Pinch Screw
200538c	14193	Presser Bar Spring Regulating Screw
200948F	14193	Presser Bar Spring Support Screw
201954	—	Roller Presser, $\frac{3}{8}$ in. diam., $\frac{1}{8}$ in. face
201955	14193	Roller Presser 201954 with 1528J, 201699J, 350104c and twenty-eight 206417
203422	14193	Roller Presser Arm
237816	—	“ “ “ 203422 with 201955
237817	—	Roller Presser Arm Bracket 202560 with 200096D and 237816

No.	Plate	Name
200675c	14193	Roller Presser Arm Bracket Posi- tion Screw Stud
202558	14193	Roller Presser Arm Bracket Spring
202559	14193	“ “ “ “ “ “ Stop
200141F	11607	Roller Presser Arm Bracket Spring Stop Screw
202560	14193	Roller Presser Arm Bracket (swing)
200096D	14193	Roller Presser Arm Screw
206417	14193	“ “ Ball, $\frac{1}{8}$ in. diameter..
201699c	14193	“ “ “ Cone
202557	14192	“ “ Bar
350104c	14193	“ “ Hinge Screw
1528J	14193	“ “ “ “ Nut
237818	—	Roller Presser and Bar complete, Nos. 200675c, 202557 to 202559, 237817 and two 200141F
237762	14193	Take-up Lever
202399	14193	“ “ Driving Stud with 202277
202277	—	Take-up Lever Driving Stud Oil Packing (wick)
202400	14193	Take-up Lever Hinge Stud with 202423
202423	—	Take-up Lever Hinge Stud Oil Packing (wick)
200363c	14193	Take-up Lever Hinge Stud Set Screw
202401	—	Take-up Lever Oiling Felt
200132E	14193	“ “ “ “ Screw ..
202402	11610	“ Disc (back)
210967	11610	“ “ (front)
210950	14193	Tension Release Driving Lever with 200394c and 202676
202676	14193	Tension Release Driving Lever Pin
237819	14193	“ “ “ “ “ “ Slide Bar
237828	—	Tension Release Driving Lever Pin Slide Bar 237819 with 200167E and 210952
202678	14193	Tension Release Driving Lever Pin Slide Bar Spring
200394c	14194	Tension Release Driving Lever Set Screw
210951	14194	Tension Release Washer
202407	10881	“ Spring
200625F	11610	“ Stud with 204925
200061c	14194	“ Stud Set Screw

No.	Plate	Name
204925	11610	Tension Stud Washer
201572B	10881	" " Thumb Nut
210953	11610	Tension complete, Nos. 200625F, 201572B, 202402, 202407, 202682, 210951 and 210967
202682	11610	Thread Controller Spring
210952	11610	" " " " Stop
200167E	11610	" " " " Screw
202412	14194	" " Guide
210954	11610	" " (lower)
210955	11610	" " (upper)
200582H	11610	" " Screw (3)
210956	11610	" " Retainer Bracket with 200397H
200582H	11610	" " " " Screw (2) ..
202091	14194	" " Sleeve
210993	11610	" " " "
202092	14194	" " Spring
223844	14194	" " " "
204058	14194	" " Stud
210957	11610	" " " "
210958	11610	" " " " Collar
200366H	14194	" " " " Set Screw
200397H	11610	" " " " " "
210959	11610	Thread Retainer (lower) complete, Nos. 210956 to 210958, 210993 and 223844
204059	—	Thread Retainer (upper) complete, Nos. 202091, 202092 and 204058 ..
237823	14194	Throat Plate, 53 elongated needle hole, for needle sizes 14 and 15, with 200178D, 200587D, 211416 and 211424, trims opposite the needle and .045, .060 and .085 in. to right of seam
211424	14194	Throat Plate Knife Follower
200587D	14194	" " " " Screw ..
211416	14194	" " " " Spring
200178D	14194	" " " " " "
691F	14194	Throat Plate Screw (2)
237744	14192	Vertical Shaft
237745	14194	" " Bevel Gear (lower)
205508	14194	" " " " " "
235857	14181	Position Pin
200396c	11607	Vertical Shaft Bevel Gear (upper) with 200374c and 200396c
200374c	14181	Vertical Shaft Bevel Gear (upper) Position Screw
		Set Screw

No.	Plate	Name
237734	14181	Vertical Shaft Bushing (lower) ..
200346c	14194	" " " " " " Set Screw
237746	14192	Vertical Shaft Bushing (upper) ..
200362c	14179	" " " " " " Set Screw
237747	14194	Vertical Shaft Driving Gear with 200374c and 200396c
200396c	11607	Vertical Shaft Driving Gear Posi- tion Screw
200374c	14181	Vertical Shaft Driving Gear Set Screw
237754	14194	Vertical Shaft Oil Leader (lower) (brass)
237755	14194	Vertical Shaft Oil Leader (upper) (brass)

LIST OF PARTS COMPLETE
FOR
MACHINE No. 110w120

VERTICAL HOOK. ROLLER PRESSER.

CONTINUOUS WHEEL FEED.

UNDEREDGE TRIMMER

For Leather Work

No.	Plate	Name
*237801	—	Arm
203091	14186	" Cap
200278H	14176	" " Screw
202248	14176	" " Washer
203089	14186	" " Spool Holder Base
203090	14186	" " " " " 203089 with 200079H and 204296
200585H	14187	Arm Cap Spool Holder Base Screw
204296	14186	" " " " Wire
200079H	14187	" " " " " Hinge Screw
203092	—	Arm Cap and Spool Holder complete, Nos. 203090, 203091 and two 200585H
204235	14187	Arm Position Pin (2)
200004E	14176	" Screw
200010E	14176	" " (2)
202005	14176	" " Washer (3)
202632	14186	" Side Plate
200462B	14176	" " Thumb Screw
237802	14189	" Shaft with 200357E and 203100
237748	14186	" " Bushing (back) with 202299
202299	—	Arm Shaft Bushing (back) Oil Packing (wick)
200071E	14176	Arm Shaft Bushing (back) Screw (3)
202245	14186	Arm Shaft Bushing (front) with 202036 and 202260
202260	—	Arm Shaft Bushing (front) Oil Packing (wick)
200502B	14176	Arm Shaft Bushing (front) Oil Packing Thumb Screw

No.	Plate	Name
202036	14176	Arm Shaft Bushing (front) Position Pin
200338c	14176	Arm Shaft Bushing (front) Set Screw
203100	—	Arm Shaft Oil Packing (wick)
200357E	14176	" " " " Stop Screw
223842	14189	Balance Wheel (belt groove 2 $\frac{3}{8}$ in. diam.) with 200328c and 200335c
200062H	14176	Balance Wheel Adjusting Screw
200328c	14176	" " Position Screw
200335c	14176	" " Set Screw
*237803	—	Bed
202258	12345	" Hinge Connection (2)
200570E	14176	" " " Screw (4)
237901	14186	" Slide (back)
237706	14186	" " (front)
203470	14176	Bobbin
*203520	—	" Case
203648	14176	" " Latch
*202056	—	" " " Pin
203473	14176	" " " Plunger
203474	14176	" " " Spring
236078	14176	" " Lever
203476	14176	" " " Eccentric
204243	14176	" " " " Position Pin
235751	14176	" " " Fulcrum
200056D	10884	" " " " Screw
203478	14176	" " " Slide Stud
203214	14176	" " Tension Spring
200984c	14176	" " " " Regulat- ing Screw
200594c	14176	Bobbin Case Tension Spring Screw
203216	—	" " Washer (cloth)
203521	14176	Bobbin Case complete, Nos. 200594c, 200984c, 202056, 203214, 203216, 203473, 203474, 203520 and 203648
237804	14186	Face Plate
202135	14176	" " Position Pin
200473B	14176	" " Thumb Screw
237707	14190	Feed Wheel
350085F	14179	" " Adjusting Screw
237708	14179	" " " " Block
237709	14180	" " Bracket
237710	14179	" " " Spring
237713	14179	" " Driving Gear with 200382c and 201220c (for 16 stitches)
201220c	14187	Feed Wheel Driving Gear Position Screw

No.	Plate	Name
200382c	14179	Feed Wheel Driving Gear Set Screw
237718	14179	" " " Pinion with 200382c and 201220c (for 16 stitches)
201220c	14187	Feed Wheel Driving Pinion Position Screw
200382c	14179	Feed Wheel Driving Pinion Set Screw
237721	14189	Feed Wheel Driving Shaft
237722	14179	" " " " Bushing (back)
237723	14179	Feed Wheel Driving Shaft Bushing (front)
200362c	14179	Feed Wheel Driving Shaft Bushing Set Screw
221743	14179	Feed Wheel Driving Shaft Collar with two 200380c
200380c	14179	Feed Wheel Driving Shaft Collar Set Screw
237724	14179	Feed Wheel Driving Shaft Gear with 200378c and 201220c
201220c	14187	Feed Wheel Driving Shaft Gear Position Screw
200378c	14179	Feed Wheel Driving Shaft Gear Set Screw
237725	14179	Feed Wheel Stud
201697c	14179	" " " Nut
*203482	—	Hook (sewing)
237726	14181	" 203482 with 201253F, 201376F and 221148
237727	—	Hook and Bobbin Case complete, Nos. 203521 and 237726
235755	14181	Hook Bevel Gear Socket, 18 teeth
235527	14181	" " " " Bushing (lower) (brass)
200362c	14179	Hook Bevel Gear Socket Bushing (lower) Set Screw
235756	14181	Hook Bevel Gear Socket Bushing (upper) (brass)
449c	14181	Hook Bevel Gear Socket Bushing (upper) Set Screw
200555H	14181	Hook Bevel Gear Socket Screw ..
235635	14181	" " " " Thrust Washer
235529	14181	Hook Driving Bevel Gear with two 350089c
350089c	14181	Hook Driving Bevel Gear Set Screw
237728	14190	" " Shaft
235857	14181	" " " Bevel Gear with 200374c and 200396c

No.	Plate	Name
237729	14180	Hook Driving Shaft Bevel Gear Housing with 200346c and three 200362c
237730	14180	Hook Driving Shaft Bevel Gear Housing Cap (bottom)
237731	14180	Hook Driving Shaft Bevel Gear Housing Cap (bottom) Gasket ..
237732	14180	Hook Driving Shaft Bevel Gear Housing Cap (side)
237733	14180	Hook Driving Shaft Bevel Gear Housing Cap (side) Gasket
200053c	14181	Hook Driving Shaft Bevel Gear Housing Cap Screw (4)
201082E	14181	Hook Driving Shaft Bevel Gear Housing Screw (long)
225532	14187	Hook Driving Shaft Bevel Gear Housing Sirew (long) Washer ..
201308E	14181	Hook Driving Shaft Bevel Gear Housing Screw (short)
200396c	11607	Hook Driving Shaft Bevel Gear Position Screw
200374c	14181	Hook Driving Shaft Bevel Gear Set Screw
237734	14181	Hook Driving Shaft Bushing (back)
200362c	14179	" " " " " " Set Screw
235531	14181	Hook Driving Shaft Bushing (front)
200347c	14181	" " " " " " Set Screw
221743	14179	Hook Driving Shaft Collar with two 200380c
200380c	14179	Hook Driving Shaft Collar Set Screw
221148	14181	Hook Gib
201376F	14181	" " Hinge Screw
201253F	14181	" " Screw
237735	14180	" Saddle with 449c, 200347c and three 200362c
235534	14182	Hook Saddle Oil Cover
201185D	14182	" " " " Screw (2) .
201318E	14182	" " " " Stop Screw (2) .
235535	—	" " Oiling Felt
202260	—	" " " Wick
235649	14182	" " " " Cover
200169H	14182	" " " " " Screw
201308E	14181	" " " " " Screw (2)
213018	—	" Washer
203507	14182	" " 213018 with 203476 and two 204243

No.	Plate	Name
208490	14190	Knee Lifter Connection Lever
200262H	14182	" " " " Hinge Screw
237766	14190	Knee Lifter Connection Lever Lift- ing Rod with 202302
202302	14182	Knee Lifter Connection Lever Lift- ing Rod Cotter Pin
237805	14189	Knee Lifter Lifting Lever
200262H	14182	" " " " Hinge Screw
207807	14187	Knife
200368H	14187	" Adjusting Screw
237932	14190	" Bar
237807	14187	" Angle Extension
200126E	14187	" " " " Screw (2)
221417	14190	" " Driving Eccentric with 200382c and 200437c
202890	14190	Knife Bar Driving Eccentric Fork with 200382c and 201464c
201464c	14187	Knife Bar Driving Eccentric Fork Position Screw
200382c	14179	Knife Bar Driving Eccentric Fork Set Screw
200437c	14187	Knife Bar Driving Eccentric Posi- tion Screw
200382c	14179	Knife Bar Driving Eccentric Set Screw
202891	14192	Knife Bar Driving Shaft Crank with 200694F and 201525E
203244	14187	Knife Bar Driving Shaft Crank Collar with two 200393c
200393c	14187	Knife Bar Driving Shaft Crank Collar Set Screw
200694F	14187	Knife Bar Driving Shaft Crank Screw Stud
201525E	14187	Knife Bar Driving Shaft Crank Screw Stud Nut
237907	14187	Knife Bar Guide Block
200011E	14187	" " " " Screw (2) ..
200404c	14187	" " " " Screw
201531E	14187	" " " " Nut
237829	14187	" " Lifting Spring
202346	14187	" " " " Plunger ..
237908	14191	" " Position Bracket
201387F	—	" " " " Screw (2) ..
237933	—	" Holder with 200368H
200898D	14191	" " Screw
237939	—	" " Switch-in Handle
200076D	14191	" Screw (2)

No.	Plate	Name
237812	14192	Knife Switch-out Handle with two 200373c
200373c	14191	Knife Switch-out Handle Set Screw
202899	14192	" " " Shaft
202900	14191	" " " Spring (spiral)
237736	14182	Needle Bar with 200141r
202552	11607	" " Connecting Link
223687	—	" " " " Oil Guard
200161D	11607	Needle Bar Connecting Link Oil Guard Screw
202333	11607	Needle Bar Connecting Link Stud with 202254
202254	—	Needle Bar Connecting Link Stud Oil Packing (wick)
200374c	11181	Needle Bar Connecting Link Stud Set Screw
200383c	14182	Needle Bar Connecting Link Stud Set Screw
*206891	—	Needle Bar Connecting Stud
202329	11607	" " " " 206891 with 200086c and 202330
202330	—	Needle Bar Connecting Stud Oil Packing (wick)
200086c	11607	Needle Bar Connecting Stud Pinch Screw
202692	14192	Needle Bar Crank with 200335c, 200374c, 200383c, 200428c and 202333
237737	—	Needle Bar Crank 202692 with 202329, 202399, 202400, 202552 and 237762
203172	11607	Needle Bar Crank Friction Washer
200428c	11607	" " " Position Screw ..
200335c	14176	" " " Set Screw
237813	14192	" " Rock Frame
237931	—	" " " " 237813 with 237736
*38127	—	Needle Bar Rock Frame Driving Eccentric
*237749	—	Needle Bar Rock Frame Driving Eccentric Body
350107c	14191	Needle Bar Rock Frame Driving Eccentric Body Position Screw..
443c	14182	Needle Bar Rock Frame Driving Eccentric Body Set Screw
21331	14182	Needle Bar Rock Frame Driving Eccentric Pressure Spring

No.	Plate	Name
21332	14182	Needle Bar Rock Frame Driving Eccentric Pressure Spring Cap..
934D	14182	Needle Bar Rock Frame Driving Eccentric Pressure Spring Cap Screw
1103C	14182	Needle Bar Rock Frame Driving Eccentric Regulating Screw
217D	14191	Needle Bar Rock Frame Driving Eccentric Set Screw
7071	14191	Needle Bar Rock Frame Driving Eccentric Set Screw Washer ...
237750	—	Needle Bar Rock Frame Driving Eccentric complete, Nos. 217D, 443c, 934D, 1103c, 7071, 21331, 21332, 38127, 237749 and 350107c
237739	14192	Needle Bar Rock Frame Driving Fork Lever with 200029E
200029E	14182	Needle Bar Rock Frame Driving Fork Lever Pinch Screw
237740	14182	Needle Bar Rock Frame Driving Fork Lever Slide Block (two pieces)
210910	11607	Needle Bar Rock Frame Hinge Stud with 202277
202277	—	Needle Bar Rock Frame Hinge Stud Oil Packing (wick)
200347C	14181	Needle Bar Rock Frame Hinge Stud Set Screw
202667	14192	Needle Bar Rock Frame Rock Shaft
210978	—	" " " " " "
		202667 with 200386c and 210920..
237910	14191	Needle Bar Rock Frame Position Bracket with 200404c and 201531E
350129E	14191	Needle Bar Rock Frame Position Bracket Screw (2)
202668	11607	Needle Bar Rock Frame Slide Block
210920	—	" " " " " "
		202668 with 201141c
201141C	14182	Needle Bar Rock Frame Slide Block Screw Stud
200386C	11607	Needle Bar Rock Frame Slide Block Screw Stud Set Screw
200141F	11607	Needle Set Screw
207072	11607	Presser Bar Bushing (2)
200352C	14182	" " " Set Screw (2)..
202671	14182	" " Lifter
200653C	14182	" " " Hinge Screw ..
202672	14191	" " Lifting Releasing Lever Bracket

No.	Plate	Name
200975F	14191	Presser Bar Lifting Releasing Lever Bracket Guide Screw
237765	14191	Presser Bar Lifting Releasing Lever Bracket Spring (spiral)
237820	14191	Presser Bar Position Guide
202338	14191	" " " " Lever with 200086F
200086F	11607	Presser Bar Position Guide Lever Pinch Screw
200352C	14182	Presser Bar Position Guide Set Screw
237821	14189	Presser Bar Spring (flat)
210949	14193	" " " Bracket with 200086c
200086C	11607	Presser Bar Spring Bracket Pinch Screw
200538C	14193	Presser Bar Spring Regulating Screw
200948F	14193	Presser Bar Spring Support Screw
201954	—	Roller Presser, $\frac{3}{8}$ in. diam., $\frac{1}{4}$ in. face
201955	14193	Roller Presser 201954 with 1528J, 201699c, 350104c and twenty-eight 206417
203422	14193	Roller Presser Arm
237816	—	" " " 203422 with 201955
237817	—	Roller Presser Arm Bracket 202560 with 200096D and 237816
200675C	14193	Roller Presser Arm Bracket Position Screw Stud
202558	14193	Roller Presser Arm Bracket Spring
202559	14193	" " " " " "
		Stop
200141F	11607	Roller Presser Arm Bracket Spring Stop Screw
202560	14193	Roller Presser Arm Bracket (swing)
200096D	14193	Roller Presser Arm Screw
206417	14193	" " Ball, $\frac{1}{8}$ in. diameter..
201699C	14193	" " " Cone
202557	14192	" " Bar
350104C	14193	" " Hinge Screw
1528J	14193	" " " " Nut
237818	—	Roller Presser and Bar complete, Nos. 200675c, 202557 to 202559, 237817 and two 200141F
237762	14193	Take-up Lever
202399	14193	" " Driving Stud with 202277

No.	Plate	Name
202277	—	Take-up Lever Driving Stud Oil Packing (wick)
202400	14193	Take-up Lever Hinge Stud with 202423
202423	—	Take-up Lever Hinge Stud Oil Packing (wick)
200363c	14193	Take-up Lever Hinge Stud Set Screw
202401	—	Take-up Lever Oiling Felt
200132E	14193	" " " " Screw ..
202402	11610	Tension Disc (back)
210967	11610	" " (front)
210950	14193	" Release Driving Lever with 200394c and 202676
202676	14193	Tension Release Driving Lever Pin
237819	14193	" " " " "
		Slide Bar
237828	—	Tension Release Driving Lever Pin Slide Bar 237819 with 200167E and 210952
202678	14193	Tension Release Driving Lever Pin Slide Bar Spring
200394c	14194	Tension Release Driving Lever Set Screw
210951	14194	Tension Release Washer
202407	10881	" Spring
200625F	11610	" Stud with 204925
200061c	14194	" " Set Screw
204925	11610	" " Washer
201572B	10881	" Thumb Nut
210953	11610	Tension complete, Nos. 200625F, 201572B, 202402, 202407, 202682, 210951 and 210967
202682	11610	Thread Controller Spring
210952	11610	" " " Stop
200167E	11610	" " " " Screw
202412	14194	" Guide
210954	11610	" " (lower)
210955	11610	" " (upper)
200582H	11610	" " Screw (3)
210956	11610	" Retainer Bracket with 200397H ..
200582H	11610	" " " Screw (2) ..
202091	14194	" " Sleeve
210993	11610	" " "
202092	14194	" " Spring
223844	14194	" " "
204058	14194	" " Stud
210957	11610	" " "
210958	11610	" " " Collar
200366H	14194	" " " Set Screw

No.	Plate	Name
200397H	11610	Thread Retainer Stud Set Screw..
210959	11610	Thread Retainer (lower) complete, Nos. 210956 to 210958, 210993 and 223844
204059	—	Thread Retainer (upper) complete, Nos. 202091, 202092 and 204058..
237934	—	Throat Plate Body, for trimming opposite the needle and .040 and .050 in. to right of seam
237935	—	Throat Plate Knife Cutting Bar, 56 elongated needle hole, for needle sizes 12 and 13, trims opposite the needle and .040 in. to right of seam
200583H	14194	Throat Plate Knife Cutting Bar Screw
691F	14194	Throat Plate Screw (2)
237936	14194	Throat Plate complete, 56 elongated needle hole, for needle sizes 12 and 13, trims opposite the needle and .040 in. to right of seam, Nos. 237934, 237935 and two 200583H
237744	14192	Vertical Shaft
237745	14194	" " Bevel Gear (lower)
205508	14194	" " " " " "
		Position Pin
235857	14181	Vertical Shaft Bevel Gear (upper) with 200374c and 200396c
200396c	11607	Vertical Shaft Bevel Gear (upper) Position Screw
200374c	14181	Vertical Shaft Bevel Gear (upper) Set Screw
237734	14181	Vertical Shaft Bushing (lower) ...
200346c	14194	" " " " Set Screw
237746	14192	Vertical Shaft Bushing (upper) ...
200362c	14179	" " " " Set Screw
237747	14194	Vertical Shaft Driving Gear with 200374c and 200396c
200396c	11607	Vertical Shaft Driving Gear Position Screw
200374c	14181	Vertical Shaft Driving Gear Set Screw
237754	14194	Vertical Shaft Oil Leader (lower) (brass)
237755	14194	Vertical Shaft Oil Leader (upper) (brass)

ACCESSORIES

FOR MACHINE No. 110w115

No.	Plate	Name
203470	14176	Bobbin (5)
*225482	—	" Case Screw Driver Blade ...
*225483	—	" " " " Handle
225497	12345	Bobbin Case Screw Driver complete, Nos. 225482 and 225483 ..
237714	—	Feed Wheel Driving Gear with 200382c and 201220c (for 17½ stitches)
237715	—	Feed Wheel Driving Gear with 200382c and 201220c (for 19 stitches)
237719	—	Feed Wheel Driving Pinion with 200382c and 201220c (for 17½ stitches)
237720	—	Feed Wheel Driving Pinion with 200382c and 201220c (for 19 stitches)
207805	14187	Knife (3)
4822	14195	Roller Presser Hinge Screw Nut Wrench
16 x 4	—	Needles, two each, sizes 12, 14 and 16
237757	—	Drip Pan with four wood screws ½ in., No. 5
41400	12345	Machine Rest Pin (wood)
36578	12345	Oiler with 36579
36579	12345	" Spout, 3½ in. long, with 120117
120117	—	" " Washer (leather)
*225484	—	Screw Driver Blade
*225485	—	" " Handle
225498	12345	Screw Driver complete, (7¼ in. long), Nos. 225484 and 225485 ..
225554	12345	Wrench (steel)

BOBBIN WINDER

Swing Automatic, Right Hand

225453	10884	Frame with 202277 and 225438 ...
225454	10884	" Hinge Pin
202277	—	" Oil Packing (wick)

No.	Plate	Name
225438	10884	Frame Oil Well Cap
225455	10884	" Spring
225456	10884	" " Plunger
202473	10885	Pulley with 200105c
200105c	10884	" Set Screw
225381	10884	Spindle
225444	10884	Stop Latch
200056E	10884	" " Screw
225458	10884	" " Thumb Lever
225459	10884	" " " " Hinge Stud
225460	10884	" " " " Joint Stud
202478	10884	" " Trip Lever
200299H	10884	" " " " Hinge Screw
225461	10881	Tension Bracket with 201499B
200082D	10881	" " Screw
228026	10884	" " " Washer
2102	10881	" Disc
202407	10881	" Spring
201499B	10881	" Stud
201572B	10881	" " Thumb Nut
225462	10881	Bobbin Winder Tension Bracket complete, Nos. 201572B, 202407, 225461 and two 2102
225433	10885	Bobbin Winder and Tension Bracket Base
225382	10885	Universal Bobbin Winder complete, Nos. 200056E, 200082D, 200299H, 202473, 202478, 225381, 225433, 225444, 225453 to 225456, 225458 to 225460, 225462, 228026 and two wood screws ¾ in., No. 13, R.H.B.

KNEE LIFTER

227781	14189	Knee Lifter Rock Lever with 200522c and 200529c
227782	—	Knee Lifter Rock Lever 227781 with two each 202451 and 202452 ...
227787	14189	Knee Lifter Rock Lever 227782 with 202203 and 227784
202453	14189	Knee Lifter Rock Lever Knee Plate with 200526c
202203	—	Knee Lifter Rock Lever Knee Plate 202453 with 202454
202454	14189	Knee Lifter Rock Lever Knee Plate Arm
200522c	14195	Knee Lifter Rock Lever Knee Plate Arm Set Screw

No.	Plate	Name
200526c	14195	Knee Lifter Rock Lever Knee Plate Set Screw
202451	14189	Knee Lifter Rock Lever Lug with two wood screws $\frac{3}{4}$ in., No. 13H
202452	14195	Knee Lifter Rock Lever Lug Hinge Pin
227784	14189	Knee Lifter Rock Lever Rod, 3 in. long, with 227785
*227785	---	Knee Lifter Rock Lever Rod Cap or Oil Guard
200529c	14195	Knee Lifter Rock Lever Rod Set Screw

(Other Knee Lifter parts are listed with parts of machine head)

FOR MACHINE No. 110w120

Same as for No. 110w115 with the following exceptions:

207807	14187	Knife (3), in place of 207805
16 x 4	---	Needles, three each, sizes 12 and 14, in place of two each, sizes 12, 14 and 16

FEED GEARS

No.	Plate	Name
237763	14195	Feed Wheel Driving Gear with 200382c and 201220c (for 12 stitches)
237711	---	Feed Wheel Driving Gear with 200382c and 201220c (for 14 stitches)
237712	---	Feed Wheel Driving Gear with 200382c and 201220c (for 15 stitches)
237713	14179	Feed Wheel Driving Gear with 200382c and 201220c (for 16 stitches)
237714	---	Feed Wheel Driving Gear with 200382c and 201220c (for 17 $\frac{1}{2}$ stitches)
237715	---	Feed Wheel Driving Gear with 200382c and 201220c (for 19 stitches)
237751	---	Feed Wheel Driving Gear with 200382c and 201220c (for 23 stitches)
237764	14195	Feed Wheel Driving Pinion with 200382c and 201220c (for 12 stitches)
237716	---	Feed Wheel Driving Pinion with 200382c and 201220c (for 14 stitches)
237717	---	Feed Wheel Driving Pinion with 200382c and 201220c (for 15 stitches)
237718	14179	Feed Wheel Driving Pinion with 200382c and 201220c (for 16 stitches)
237719	---	Feed Wheel Driving Pinion with 200382c and 201220c (for 17 $\frac{1}{2}$ stitches)
237720	---	Feed Wheel Driving Pinion with 200382c and 201220c (for 19 stitches)
237752	---	Feed Wheel Driving Pinion with 200382c and 201220c (for 23 stitches)

Throat Plates

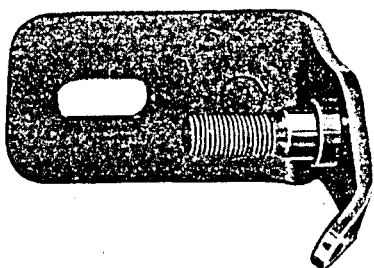
No.	Plate	Name
237935	—	Throat Plate Knife Cutting Bar, 56 elongated needle hole, for needle sizes 12 and 13, trims opposite the needle and .040 in. to right of seam, for 237936
237929	—	Throat Plate complete, 56 elongated needle hole, for needle sizes 12 and 13, trims back of needle and .040 in. to right of seam, Nos. 237922, 237925 and two 200583H..
237936	14194	Throat Plate complete, 56 elongated needle hole, for needle sizes 12 and 13, trims opposite the needle and .040 in. to right of seam, Nos. 237934, 237935 and two 200583H..

OBSOLETE PARTS

237758	—	Knee Lifter Connection Lever Lifting Rod with 202302
237906	—	Knife Bar, for Machine No. 110w120
237909	14191	" Holder with 200368H, for Machine No. 110w120

PLATE 10881—FULL SIZE

225461



200082



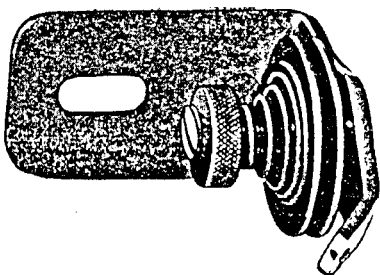
202104



2102



225462



202407



201499

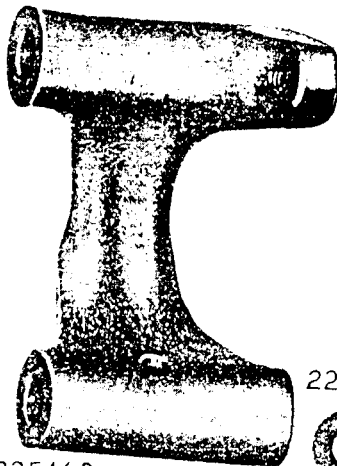


201572

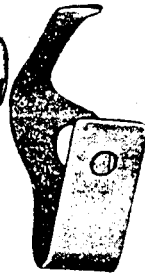


PLATE 10884—FULL SIZE

225453



225444



202478



228026



225458



225460



225454



200299



225438



200056



225459



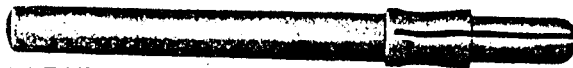
200105



225456



225381



225455

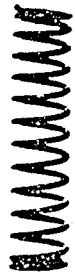


PLATE 10885—ONE-FOURTH SIZE

225433

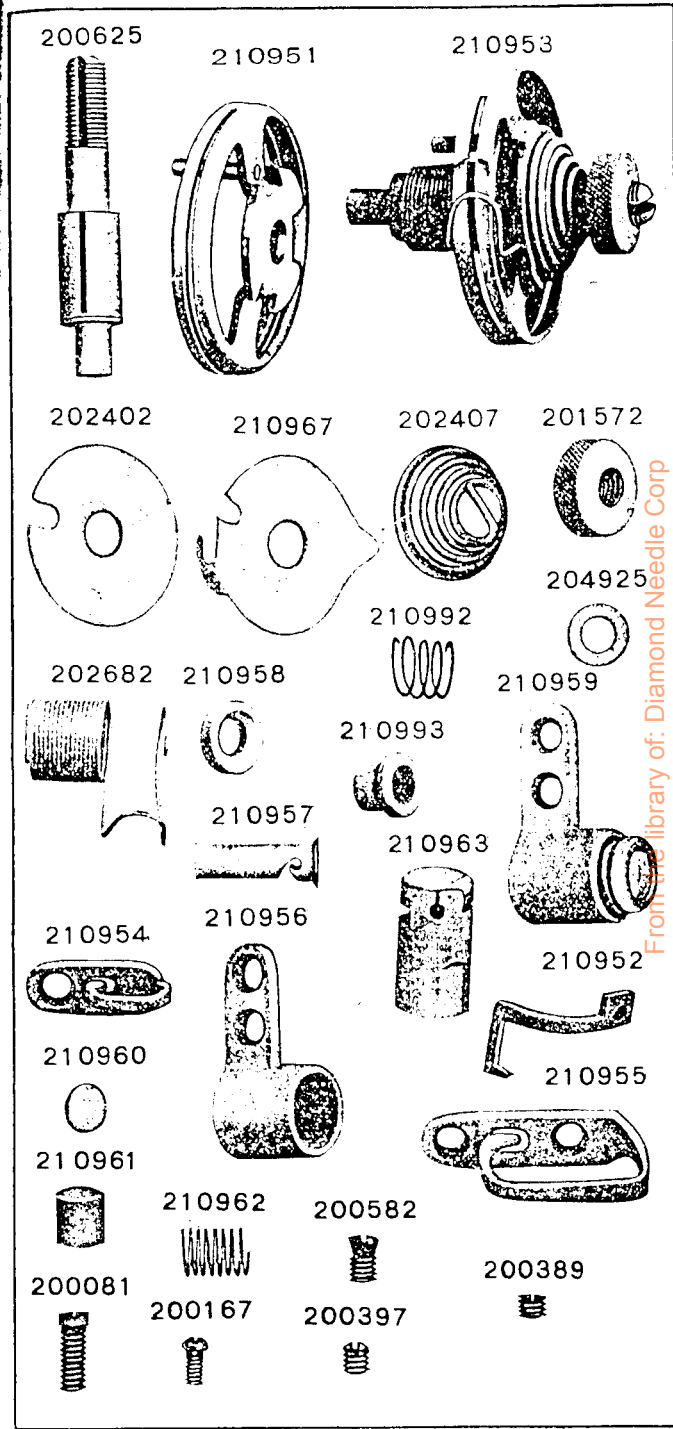
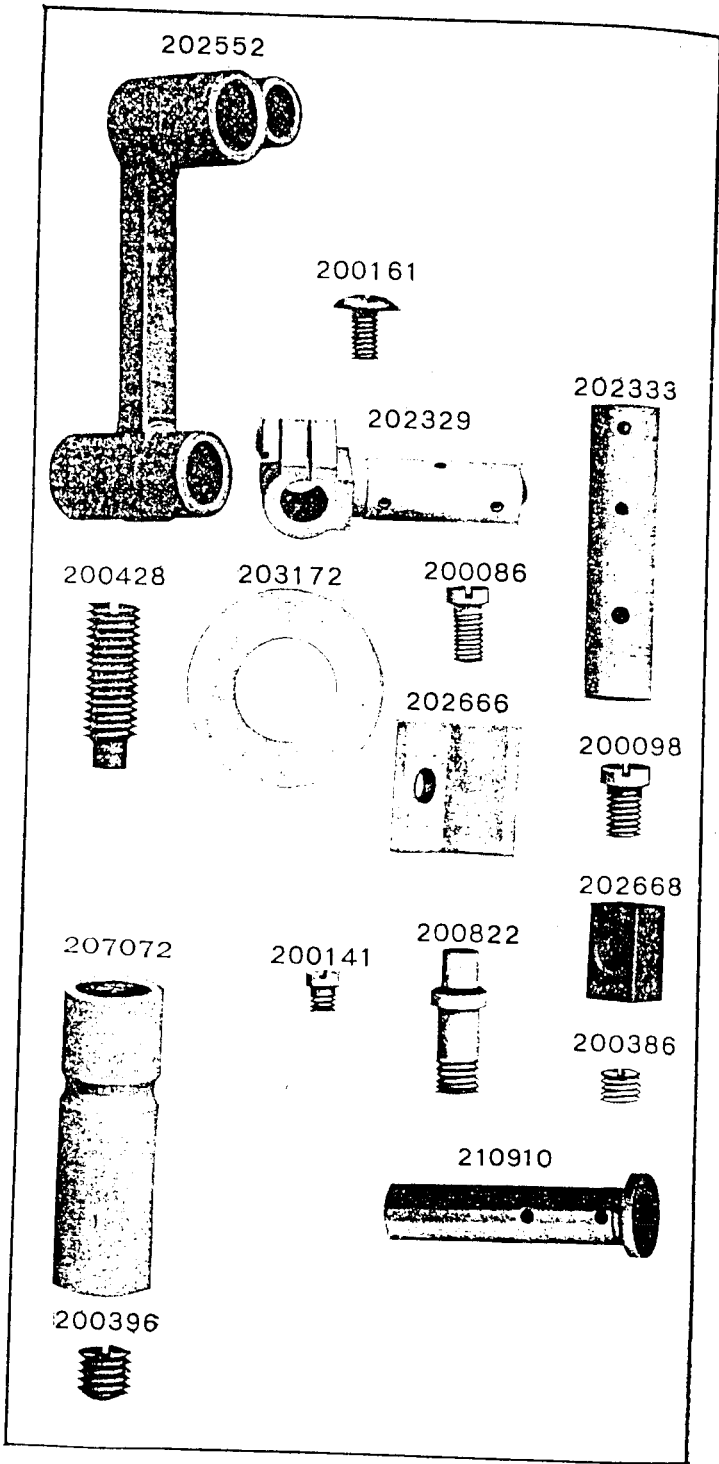


202473



225382





From the library of: Diamond Needle Corp

PLATE 12345—ONE-HALF SIZE

PLATE 14176—FULL SIZE

41400



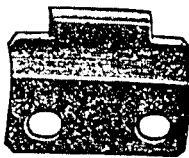
225498



225497



202258

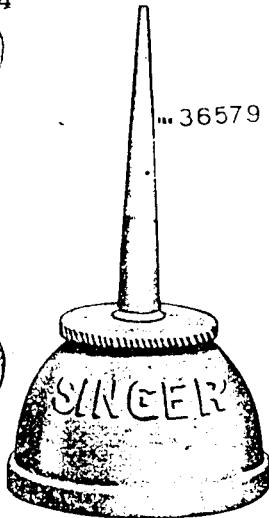


36578

225554



36579



200278 202248 200071 202036 200338

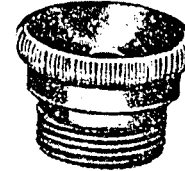


8582

200502

200357

200462

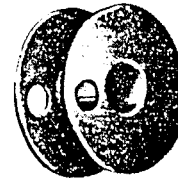


203470

200062

200328

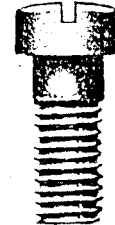
200010



200335



203473



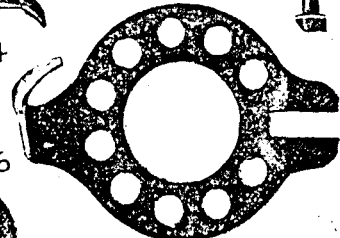
203648

236078

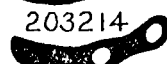


200004

203474



203476



203214

235751

200984 200594

200570



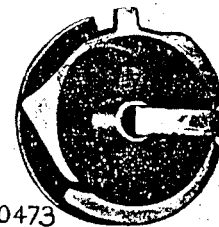
203521

202005



203478

200473



204243



202135

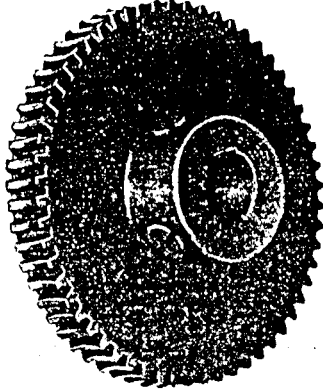
From the library of: Diamond Needle Corp

PLATE 14179—FULL SIZE

237723



237724



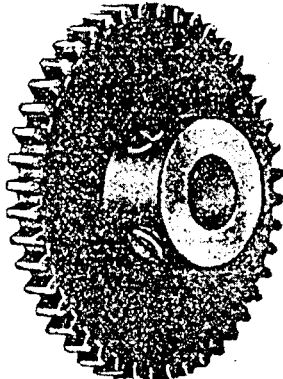
200378



200382



237713



201220



200362



200380



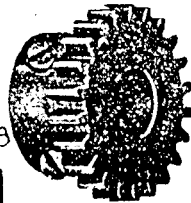
237722



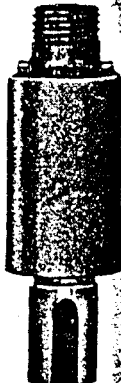
221743



237718



237725



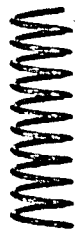
237708



350085



237710

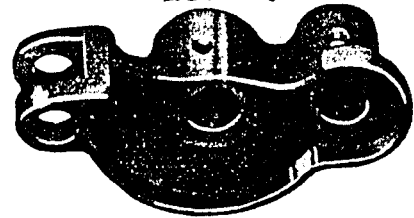


201697

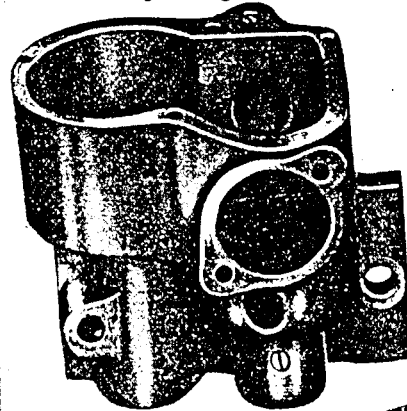


PLATE 14180—ONE-HALF SIZE

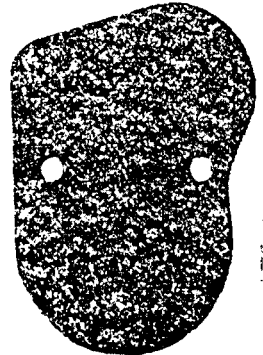
237709



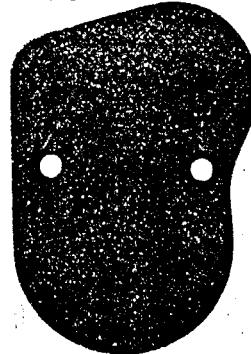
237729



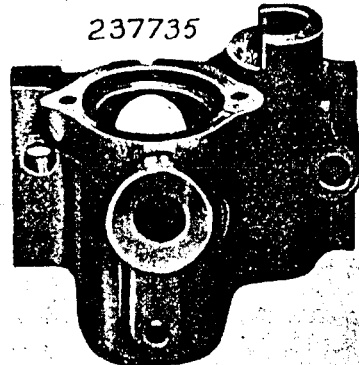
237733



237732



237735



237730



237731

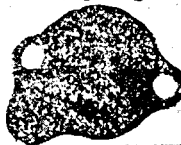
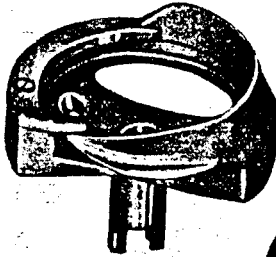


PLATE 14181—FULL SIZE

237726

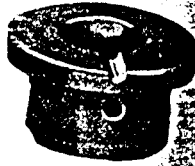


235527



235635

235756

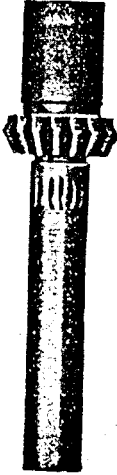


200485

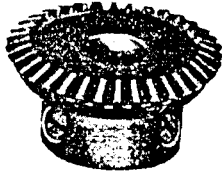
449



235755



235529



201308



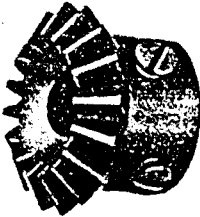
350089



200053



235857



201082



237734

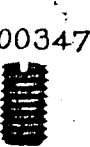


200374



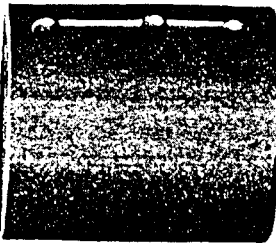
201376

201253



200347

235531



200555

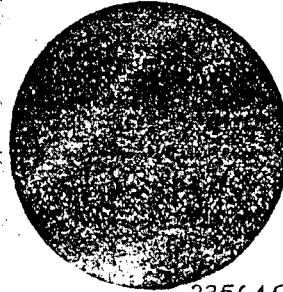


221148



PLATE 14182—FULL SIZE

235534



201185

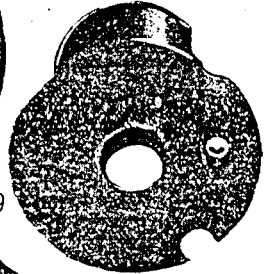


200169



237736

203507



201318



235649



21331

934

202302

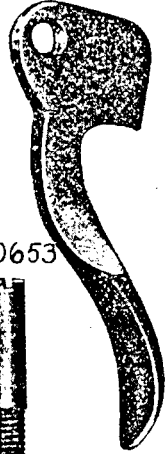


202671



200262

21332



202446



200224



1103

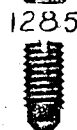


200653



200383 200029

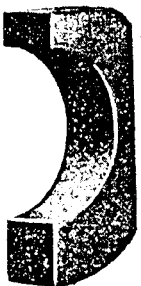
1285



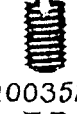
196



237740



443



201141

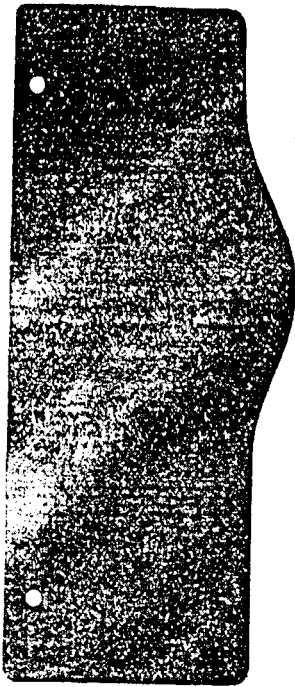


200352

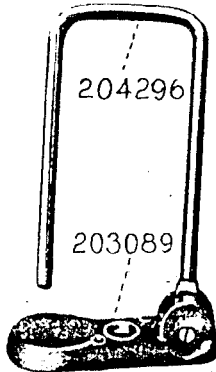


PLATE 14186—ONE-HALF SIZE

237804

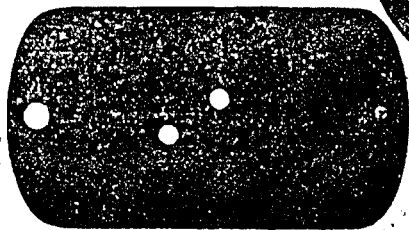


203090



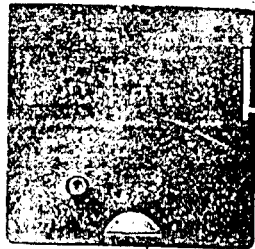
204296

203089



203091

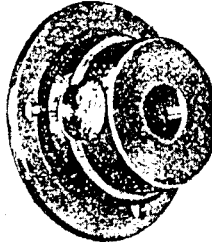
237901



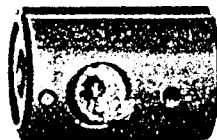
237706



237748



202245



202632

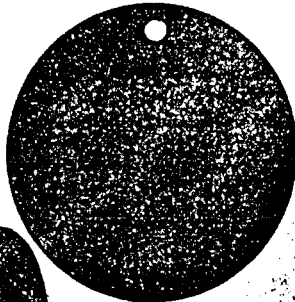


PLATE 14187—FULL SIZE

200585



200079



204235



201220



200246



200368



200126



201464



200437



200393



200694



225708



225532



2023



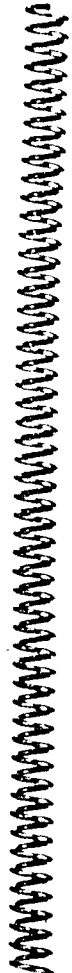
200337



207807



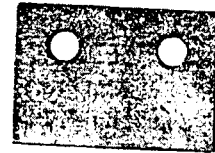
237807 237829



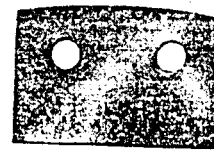
201525



237808



237907



203244



207805



200011



201531



200404



From the Gray of Brown to the White of Gray

PLATE 14188—FULL SIZE

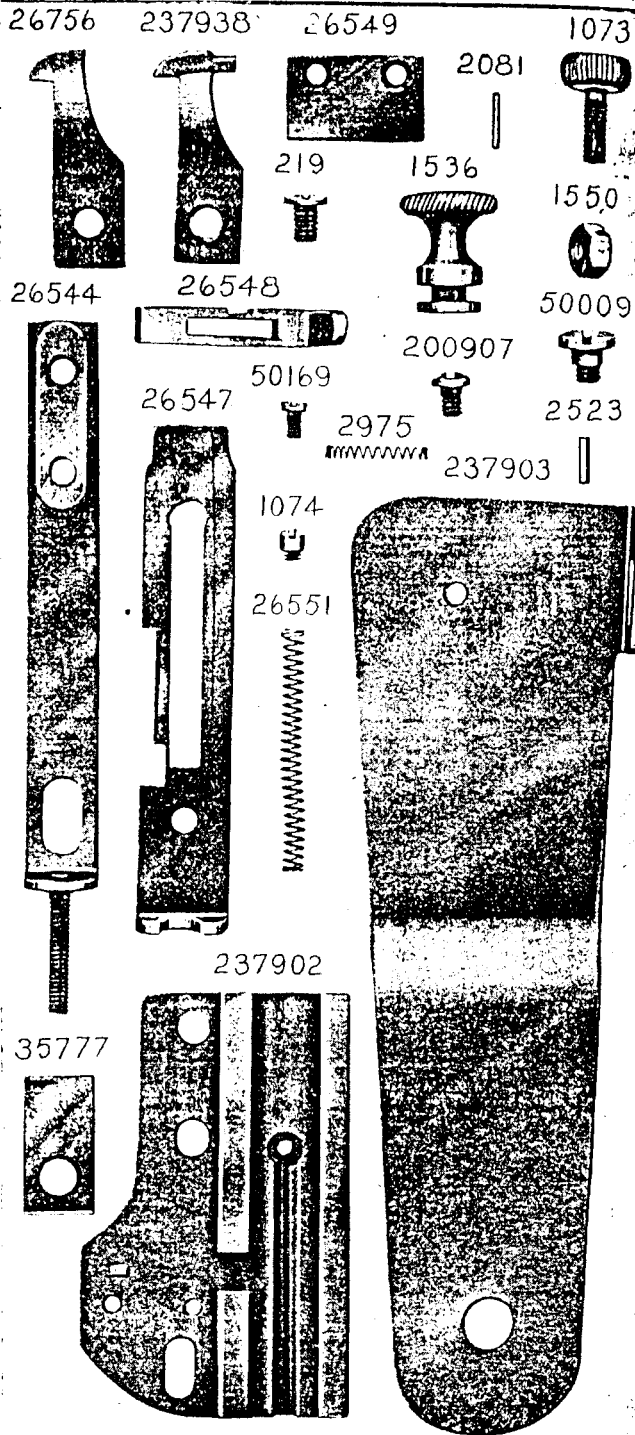


PLATE 14189—ONE-FOURTH SIZE

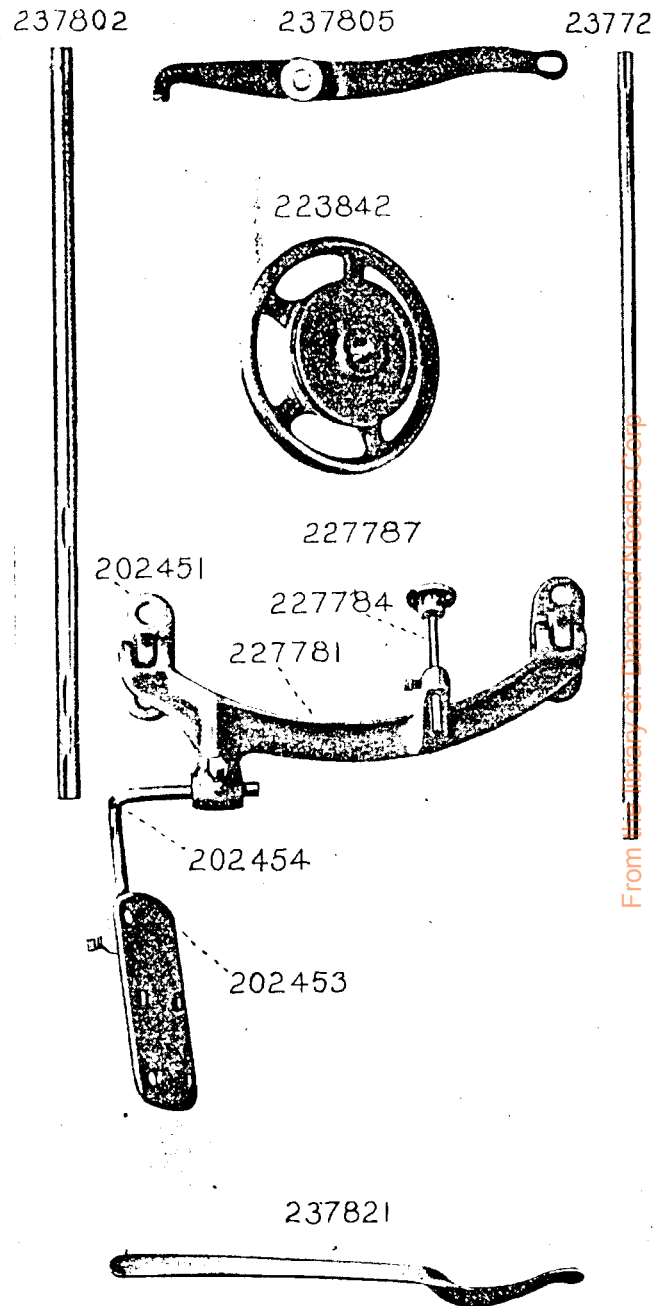
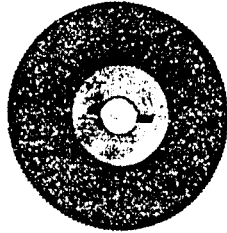


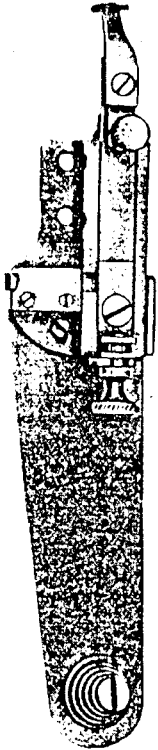
PLATE 14190—ONE-HALF SIZE

237707
237767 237728

237766



237905



221417



237806



237932



208490



202890

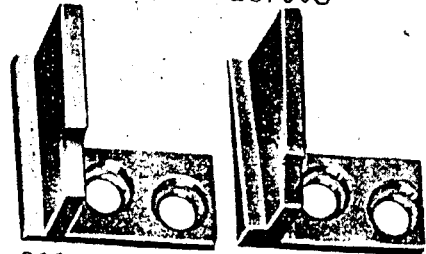


PLATE 14191—FULL SIZE

237809

237908

237811



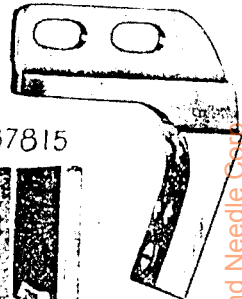
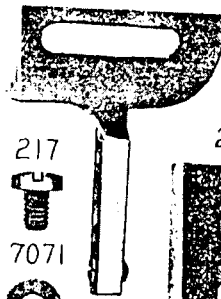
200084

237810

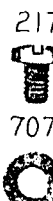
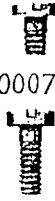
237909



200898



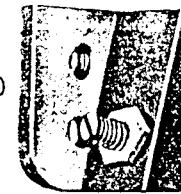
200076



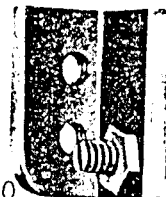
200373



237910



237815



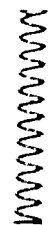
200975



202900



237765



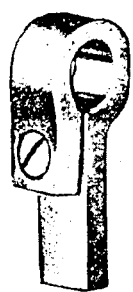
237820



202672



202338



350107



350129



From the library of the National Needle Co.

PLATE 14192—ONE-HALF SIZE

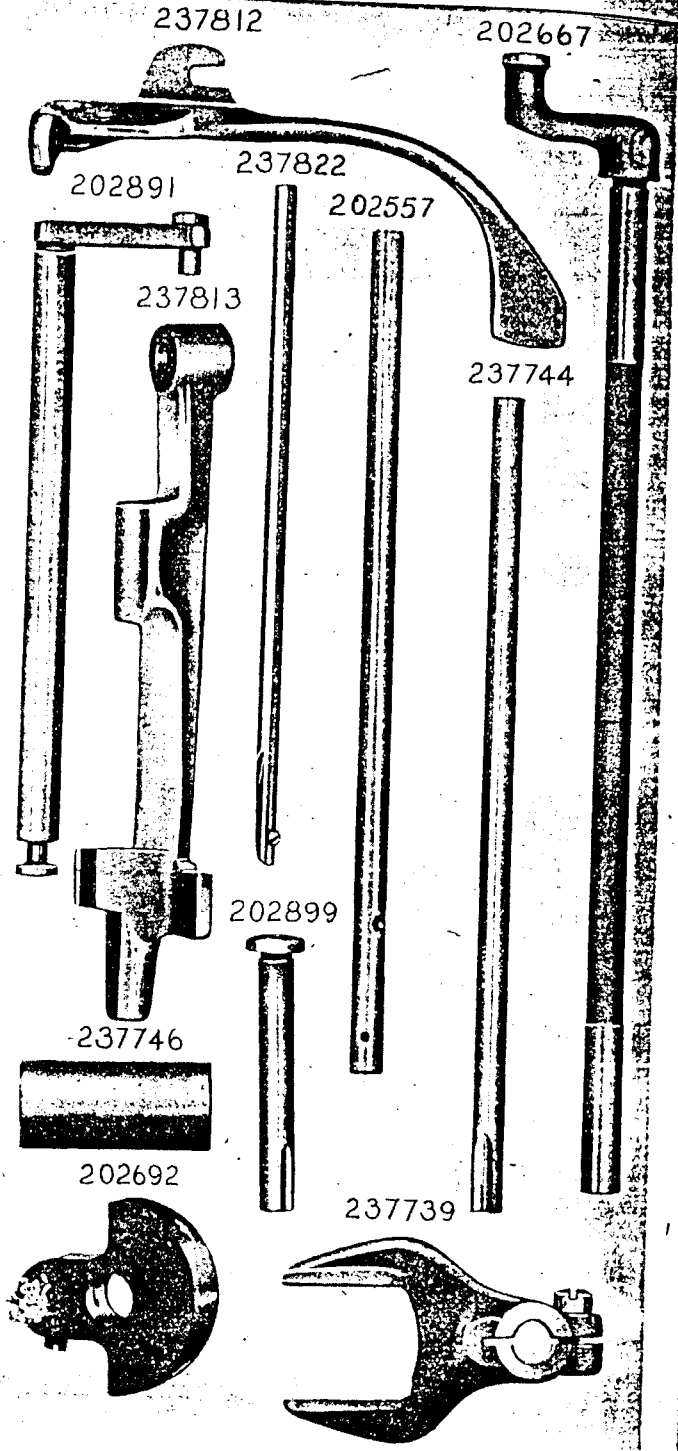


PLATE 14193—FULL SIZE

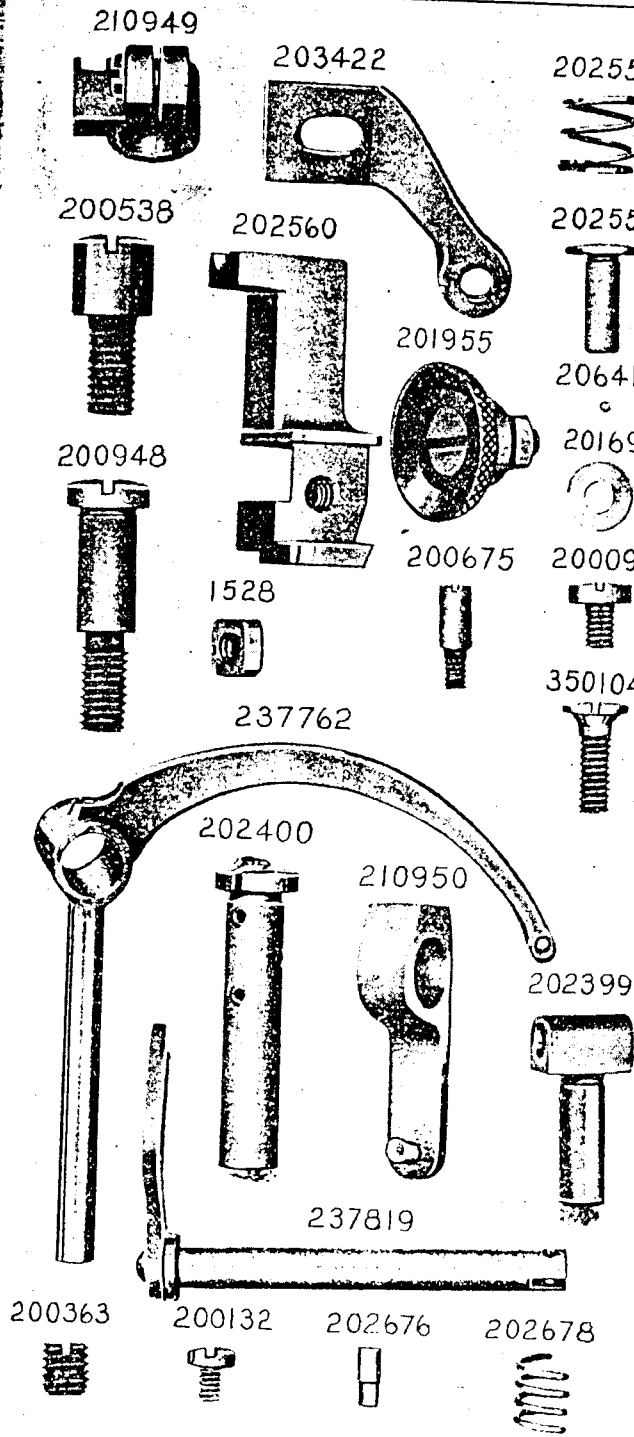
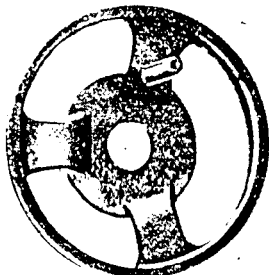


PLATE 14194—FULL SIZE

202412

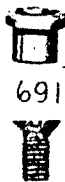


210951



237823

202091

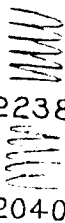


691

200587



202092



223844

204058



200394



200061



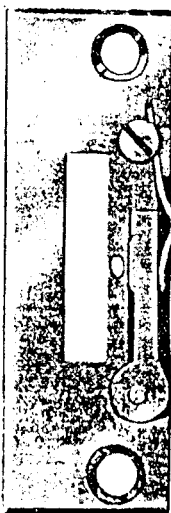
200366



200583



211424



237745

237936

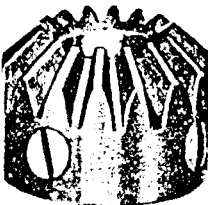


237755

237754



237747



205508



200346



200178

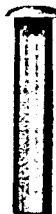


PLATE 14195—FULL SIZE

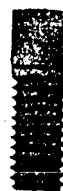
4822



202452



200522



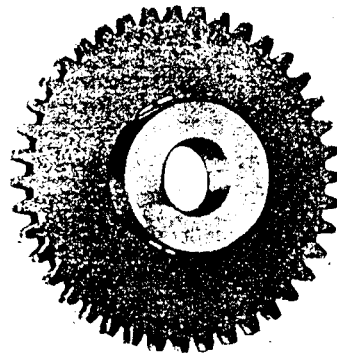
200526



200528



237763



237764

